

# INSTALLATION INSTRUCTIONS

FOR ITEM 149550

*Meyda*  
CUSTOM LIGHTING

**CAUTION: FAILURE TO INSTALL THIS FIXTURE PROPERLY MAY RESULT IN SERIOUS PERSONAL INJURY OR DEATH AND PROPERTY DAMAGE.** We recommend installation by a licensed electrician.

This product must be installed in accordance with applicable installation code(s), by a person familiar with the construction and operation of the product and the hazards involved.\*

**Caution:** Do not exceed maximum wattage noted on fixture. Use only recommended bulbs with fixture.

## FIXTURE COMPONENTS

1. FRAME W/ LIGHT CLUSTER INSTALLED
2. CANOPY ASSEMBLY W/ MOUNTING PLATE

### **Caution:**

**Fixture is OVERWEIGHT and not suitable for installation with standard Junction Box.**

**Be sure power is off at the main breaker box prior to installation.**

**Read all instructions in their entirety before beginning installation.**

1. Carefully unpack all components and make certain that everything is on hand.
2. Separate the mounting plate by removing the acorn nuts and hex nuts, keep them for later.
3. Using customer supplied hardware, affix mounting plate to ceiling ensuring that the connection is suitable to hold a minimum of 55 lbs and that electrical supply wires remain accessible.
4. Screw in the running thread into the coupling attached to the frame's crossbar, simultaneously pushing the lead wires through the running thread.
5. Take the tube and slide it over the running thread. Put the check ring on top of it.
6. Take the canopy and slide over the running thread and secure all by using spider-washer and hex nut provided.
7. Lift the shade up and secure to the mounting plate using hex nut and acorn nuts from earlier.
8. Unscrew the knurled knob on the canopy to remove the wiring access panel to get access to lead wires from fixture and supply wires.
9. Following all local codes and procedures, make electrical connection from Fixture lead wires to Supply wires.
10. Screw back the wiring access panel using the Knurled knob.
11. Power on and ENJOY!



# CUSTOMER PROPOSAL / CUT SHEET

"A Commitment to Excellence in Lighting and Service"

REVISION:

CALL OUR CUSTOMER SERVICE DEPARTMENT AT 1-800-222-4009  
 MONDAY - FRIDAY 9:00a.m - 5:00p.m ET  
 visit us on the web at www.meyda.com

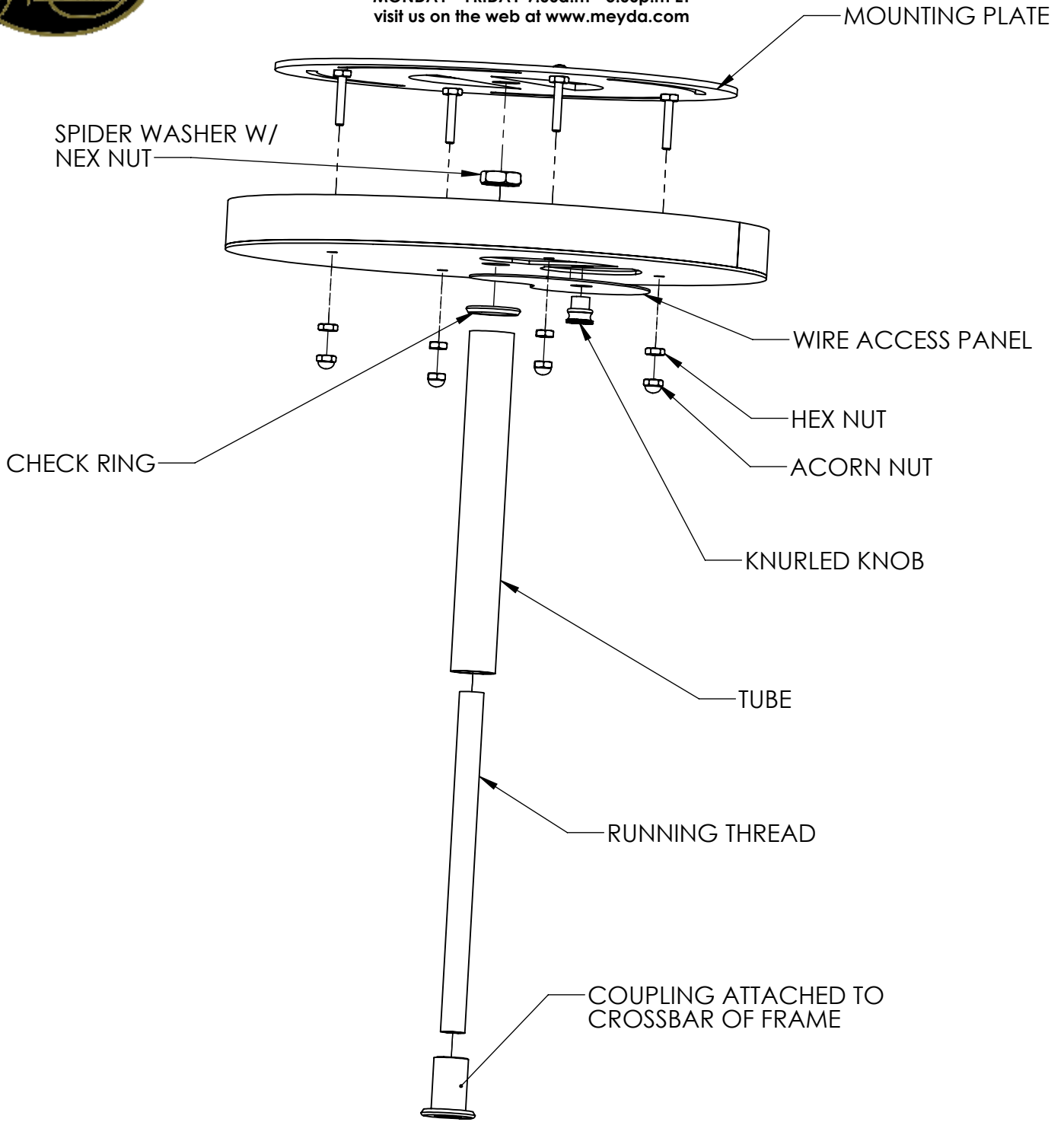

\*DIMENSIONS AND DETAILS ARE SUBJECT TO MODIFICATION DURING PRODUCTION  
 © MEYDA TIFFANY INC © DESIGN COPYRIGHT, MEYDA TIFFANY, INC. ALL RIGHTS RESERVED, NO UNAUTHORIZED DUPLICATION



\*TRANSPARENT FINISHES WILL VARY DEPENDING ON THE MATERIAL TO WHICH IT IS APPLIED AND THE FABRICATION TECHNIQUE.

ID# 869-2(149550)	W/O# 1514482	BULB# 4 (BULBS NOT INCLUDED)	DATE:3/20/2025
CUST. DESIGN#	QTY: 1	TYPE: E26 A19	DRAWN BY:TP1063
FIXTURE TYPE:SEMI-FLUSH MOUNT	WATTS:60	VOLTAGE:120	SCALE: 1:3
LENS COLOR:618770 HONEY AMBER	TOTAL AMPS:2	APPROVAL:	
METAL FINISH:3ANCOP ANTIQUE COPPER (106387) (TRANSPARENT)	LOCATION: DAMP	EST. WEIGHT:49.27 LBS	
MATERIAL:STEEL/ GLASS	NOTES:	SHEET: 2 OF 4	



# CUSTOMER PROPOSAL / CUT SHEET

"A Commitment to Excellence in Lighting and Service"

REVISION:

CALL OUR CUSTOMER SERVICE DEPARTMENT AT 1-800-222-4009  
 MONDAY - FRIDAY 9:00a.m - 5:00p.m ET  
 visit us on the web at www.meyda.com

USE ANY OF THESE SLOTS  
 TO AFFIX MOUNTING PLATE  
 TO CEILING

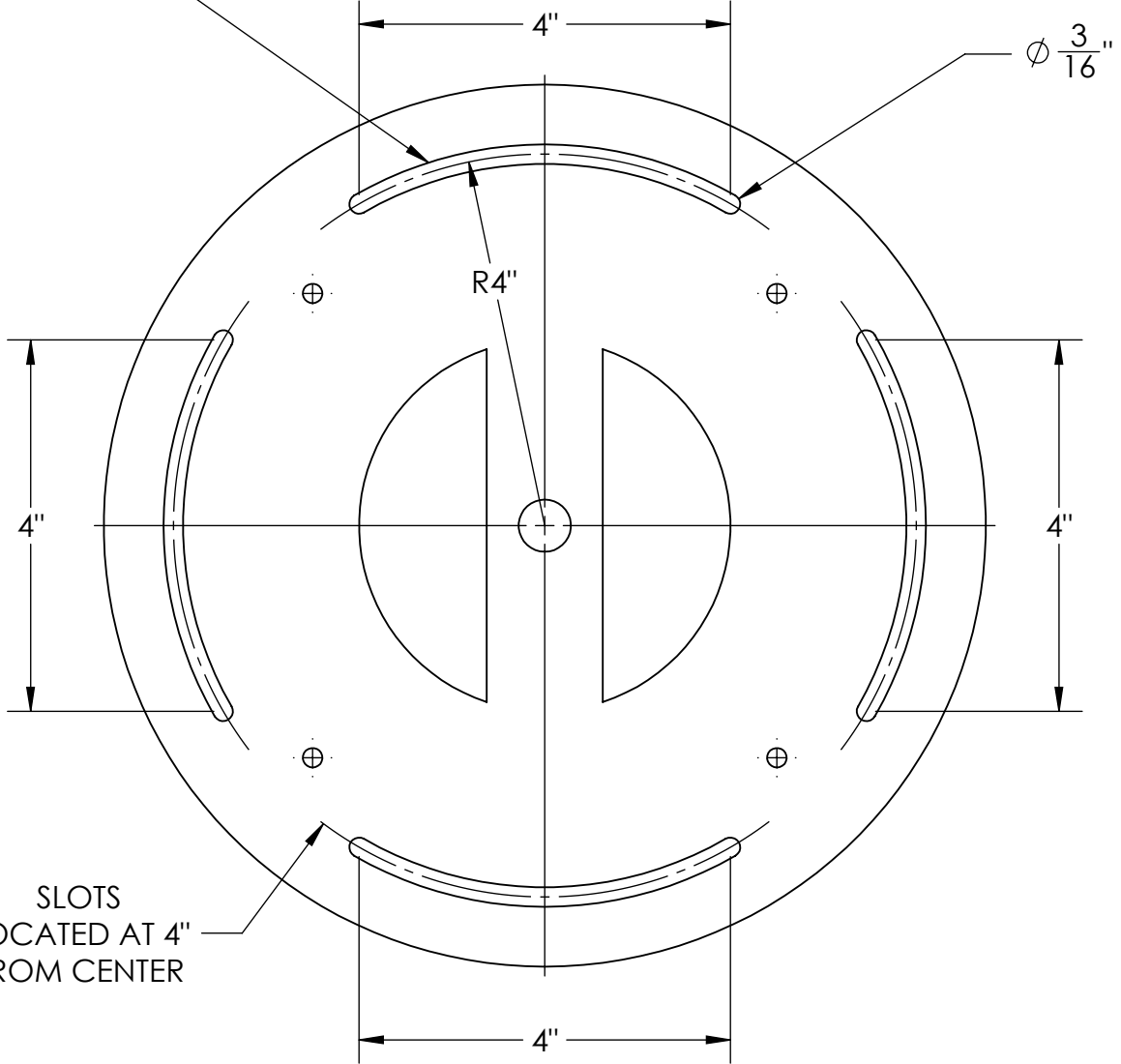

SLOTS  
 LOCATED AT 4"  
 FROM CENTER

## MOUNTING PLATE



\*DIMENSIONS AND DETAILS ARE SUBJECT TO MODIFICATION DURING PRODUCTION  
 © MEYDA TIFFANY INC © DESIGN COPYRIGHT, MEYDA TIFFANY, INC. ALL RIGHTS RESERVED, NO UNAUTHORIZED DUPLICATION  
 \*TRANSPARENT FINISHES WILL VARY DEPENDING ON THE MATERIAL TO WHICH IT IS APPLIED AND THE FABRICATION TECHNIQUE.



ID# 869-2(149550)	W/O# 1514482	BULB# 4	DATE:3/20/2025
CUST. DESIGN#	QTY: 1	TYPE: E26 A19	(BULBS NOT INCLUDED) DRAWN BY: TP1063
FIXTURE TYPE: SEMI-FLUSH MOUNT	WATTS:60	VOLTAGE:120	SCALE: 1:2
LENS COLOR:618770 HONEY AMBER	TOTAL AMPS:2	APPROVAL:	
METAL FINISH:3ANCOP ANTIQUE COPPER (106387) (TRANSPARENT)	LOCATION: DAMP	EST. WEIGHT: 49.27 LBS	
MATERIAL:STEEL/ GLASS	NOTES:	SHEET: 3 OF 4	



# CUSTOMER PROPOSAL / CUT SHEET

"A Commitment to Excellence in Lighting and Service"

REVISION:

CALL OUR CUSTOMER SERVICE DEPARTMENT AT 1-800-222-4009  
 MONDAY - FRIDAY 9:00a.m - 5:00p.m ET  
 visit us on the web at www.meyda.com

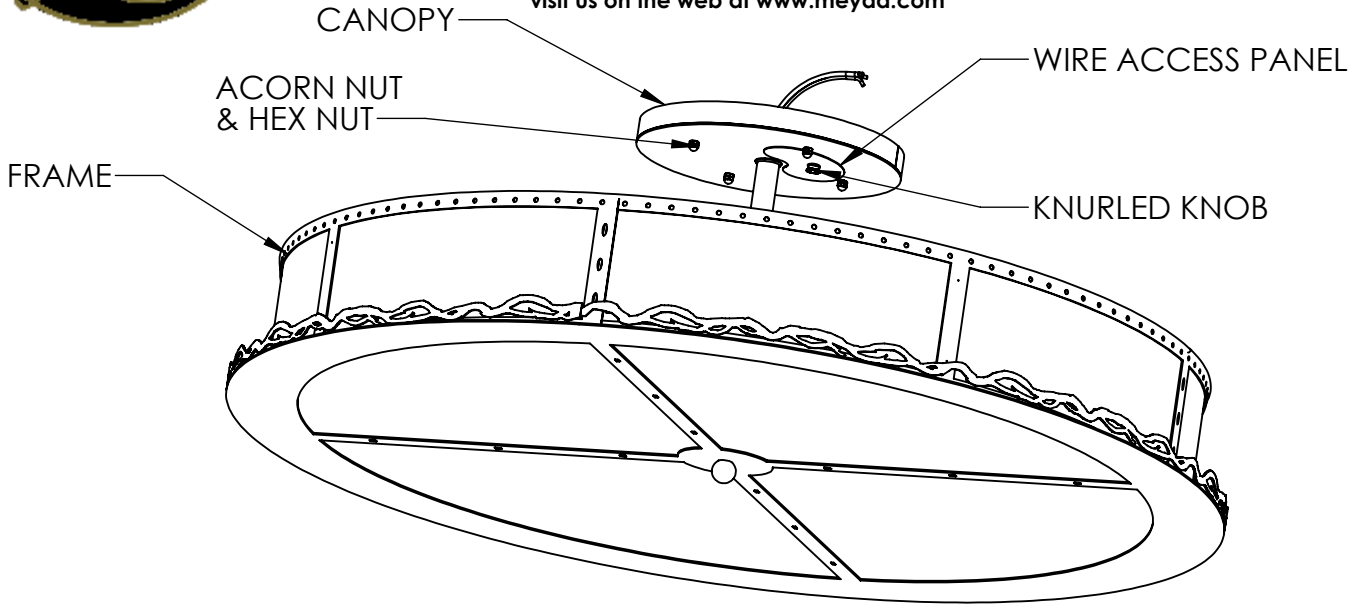

## OVERALL

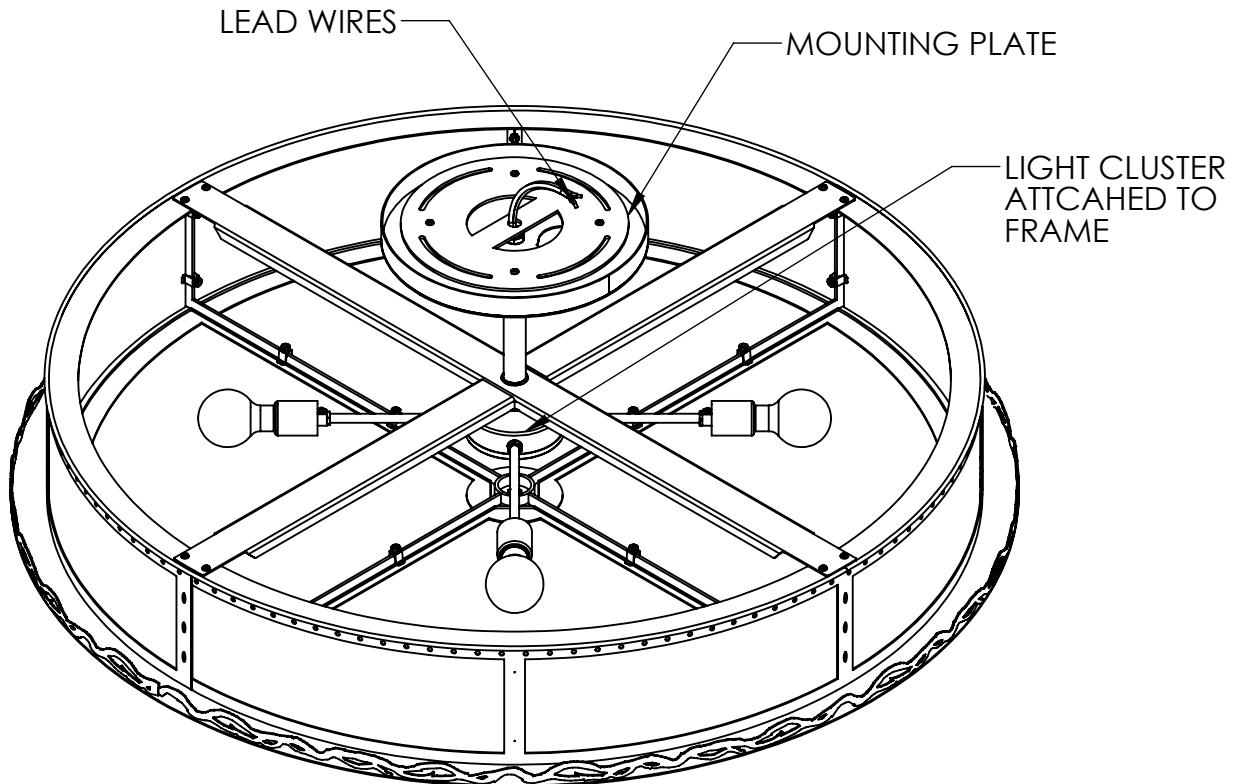

\*DIMENSIONS AND DETAILS ARE SUBJECT TO MODIFICATION DURING PRODUCTION  
 © MEYDA TIFFANY INC © DESIGN COPYRIGHT, MEYDA TIFFANY, INC. ALL RIGHTS RESERVED, NO UNAUTHORIZED DUPLICATION



\*TRANSPARENT FINISHES WILL VARY DEPENDING ON THE MATERIAL TO WHICH IT IS APPLIED AND THE FABRICATION TECHNIQUE.

ID# 869-2(149550)	W/O# 1514482	BULB# 4	DATE:3/20/2025
CUST. DESIGN#	QTY: 1	TYPE: E26 A19	(BULBS NOT INCLUDED) DRAWN BY: TP1063
FIXTURE TYPE: SEMI-FLUSH MOUNT	WATTS:60	VOLTAGE:120	SCALE: 1:8
LENS COLOR:618770 HONEY AMBER	TOTAL AMPS:2	APPROVAL:	
METAL FINISH:3ANCOP ANTIQUE COPPER (106387) (TRANSPARENT)	LOCATION: DAMP	EST. WEIGHT:49.27 LBS	
MATERIAL:STEEL/ GLASS	NOTES:	SHEET: 4 OF 4	